

Howmet Aerospace

A Differentiated Aerospace Supplier

February 25, 2020



**HOWMET
AEROSPACE**

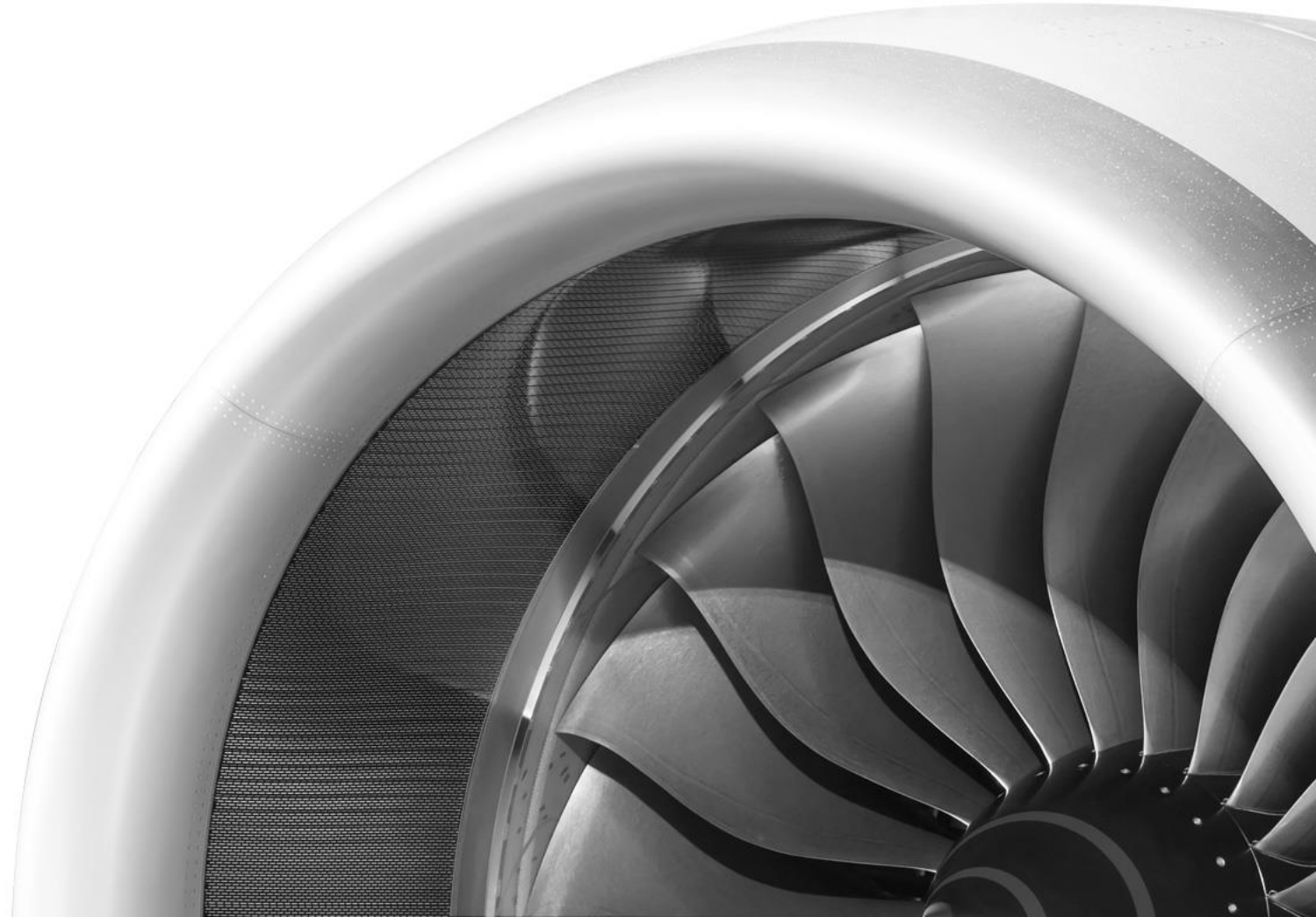

Important Information

Forward-Looking Statements

This presentation contains statements that relate to future events and expectations and as such constitute forward-looking statements within the meaning of the Private Securities Litigation Reform Act of 1995. Forward-looking statements include those containing such words as "anticipates," "believes," "could," "estimates," "expects," "forecasts," "goal," "guidance," "intends," "may," "outlook," "plans," "projects," "seeks," "sees," "should," "targets," "will," "would," or other words of similar meaning. All statements that reflect Howmet Aerospace's expectations, assumptions or projections about the future, other than statements of historical fact, are forward-looking statements, including, without limitation, forecasts and expectations relating to the growth of the aerospace, defense, automotive, industrials, commercial transportation and other end markets; statements and guidance regarding future financial results or operating performance; statements regarding future strategic actions; and statements about Howmet Aerospace's strategies, outlook, business and financial prospects. These statements reflect beliefs and assumptions that are based on Howmet Aerospace's perception of historical trends, current conditions and expected future developments, as well as other factors Howmet Aerospace believes are appropriate in the circumstances. Forward-looking statements are not guarantees of future performance and are subject to risks, uncertainties and changes in circumstances that are difficult to predict, which could cause actual results to differ materially from those indicated by these statements. Such risks and uncertainties include, but are not limited to: (a) uncertainties regarding the planned separation, including whether it will be completed pursuant to the targeted timing, asset perimeters, and other anticipated terms, if at all; (b) the impact of the separation on the businesses of Howmet Aerospace; (c) the risk that the businesses will not be separated successfully or such separation may be more difficult, time-consuming or costly than expected, which could result in additional demands on Howmet Aerospace's resources, systems, procedures and controls, disruption of its ongoing business, and diversion of management's attention from other business concerns; (d) deterioration in global economic and financial market conditions generally; (e) unfavorable changes in the markets served by Howmet Aerospace; (f) the inability to achieve the level of revenue growth, cash generation, cost savings, improvement in profitability and margins, fiscal discipline, or strengthening of competitiveness and operations anticipated or targeted; (g) competition from new product offerings, disruptive technologies or other developments; (h) political, economic, and regulatory risks relating to Howmet Aerospace's global operations, including compliance with U.S. and foreign trade and tax laws, sanctions, embargoes and other regulations; (i) manufacturing difficulties or other issues that impact product performance, quality or safety; (j) Howmet Aerospace's inability to realize expected benefits, in each case as planned and by targeted completion dates, from acquisitions, divestitures, facility closures, curtailments, expansions, or joint ventures; (k) the impact of potential cyber attacks and information technology or data security breaches; (l) the loss of significant customers or adverse changes in customers' business or financial conditions; (m) adverse changes in discount rates or investment returns on pension assets; (n) the impact of changes in aluminum prices and foreign currency exchange rates on costs and results; (o) the outcome of contingencies, including legal proceedings, government or regulatory investigations, and environmental remediation, which can expose Howmet Aerospace to substantial costs and liabilities; and (p) the other risk factors summarized in Howmet Aerospace's Form 10-K for the year ended December 31, 2018 and other reports filed with the U.S. Securities and Exchange Commission (SEC). Market projections are subject to the risks discussed above and other risks in the market. The statements in this presentation are made as of the date of this presentation, even if subsequently made available by Howmet Aerospace on its website or otherwise. Howmet Aerospace disclaims any intention or obligation to update publicly any forward-looking statements, whether in response to new information, future events, or otherwise, except as required by applicable law.

Important Information (continued)

References herein to Howmet Aerospace refer to Arconic Inc., which will be renamed “Howmet Aerospace Inc.” upon its separation from Arconic Rolled Products Corporation (to be renamed “Arconic Corporation” upon the separation).

Non-GAAP Financial Measures

Some of the information included in this presentation is derived from Howmet Aerospace’s consolidated financial information but is not presented in Howmet Aerospace’s financial statements prepared in accordance with accounting principles generally accepted in the United States of America (GAAP). Certain of these data are considered “non-GAAP financial measures” under SEC rules. These non-GAAP financial measures supplement our GAAP disclosures and should not be considered an alternative to the GAAP measure. Reconciliations to the most directly comparable GAAP financial measures and management’s rationale for the use of the non-GAAP financial measures can be found in the Appendix to this presentation. Howmet Aerospace has not provided reconciliations of any forward-looking non-GAAP financial measures, such as organic revenue, earnings per share excluding special items, adjusted free cash flow, and free cash flow conversion, to the most directly comparable GAAP financial measures because such reconciliations are not available without unreasonable efforts due to the variability and complexity with respect to the charges and other components excluded from the non-GAAP measures, such as the effects of foreign currency movements, equity income, gains or losses on sales of assets, taxes, and any future restructuring or impairment charges. These reconciling items are in addition to the inherent variability already included in the GAAP measures, which includes, but is not limited to, price/mix and volume. Howmet Aerospace believes such reconciliations would imply a degree of precision that would be confusing or misleading to investors.

“Organic revenue” is GAAP revenue adjusted for Tennessee Packaging (which completed its phase-down as of year-end 2018), divestitures, and changes in aluminum prices and foreign currency exchange rates relative to prior year period. “Adjusted free cash flow” is cash provided from (used for) operations, less capital expenditures, plus cash receipts from sold receivables. Any reference to historical EBITDA means adjusted EBITDA for which we have provided calculations and reconciliations in the Appendix.

Other Information

In the third quarter of 2019, Howmet Aerospace realigned its operations by eliminating its Transportation and Construction Solutions (TCS) segment and transferring the Forged Wheels business to the Engineered Products and Forgings (EP&F) segment (formerly named the Engineered Products and Solutions segment) and the Building and Construction Systems (BCS) business to the Global Rolled Products (GRP) segment. The Latin American extrusions business, formerly part of the TCS segment prior to its sale in April of 2018, was moved to Corporate. In the first quarter of 2019, Howmet Aerospace transferred its Aluminum Extrusions operations from the EP&F segment to the GRP segment. Prior period financial information has been recast to conform to current year presentation.

Today's Presenters

John Plant

Executive Chairman & Co-Chief Executive Officer
Howmet Aerospace



Current Chairman & Chief Executive Officer
Arconic Inc.

Ken Giacobbe

EVP & Chief Financial Officer
Howmet Aerospace



Current EVP & Chief Financial Officer
Arconic Inc.

Howmet Aerospace: Unique Assets with Iconic, Trusted Brand & Differentiated Technologies



**HOWMET
AEROSPACE**

Iconic, Trusted Brand

80+ year history – major presence in jet engines

Leading market position with high barriers to entry

Collaborative relationships across a blue-chip customer base

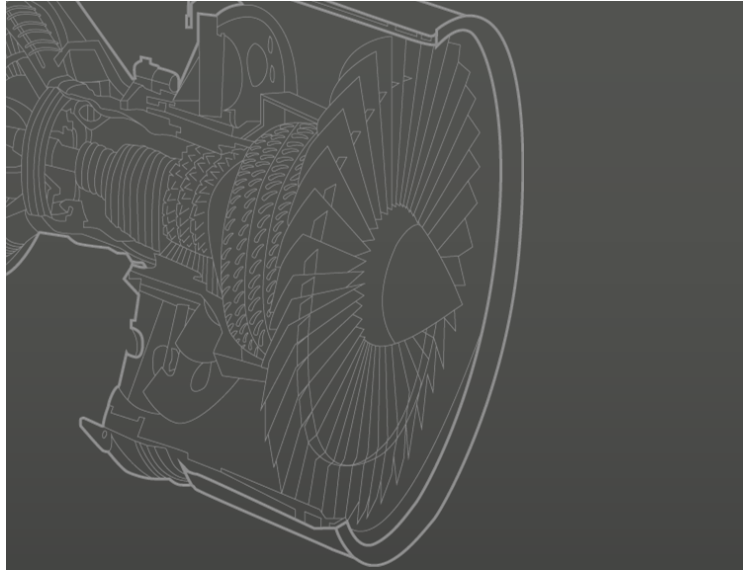

Differentiated Technologies with Rich IP Portfolio and Process Know-How

Deep customer relationships allow company to lead the technology curve

Strategic global footprint with state-of-the-art facilities

Nearly 1,300 granted and pending patents for designs and production processes drive competitive advantage

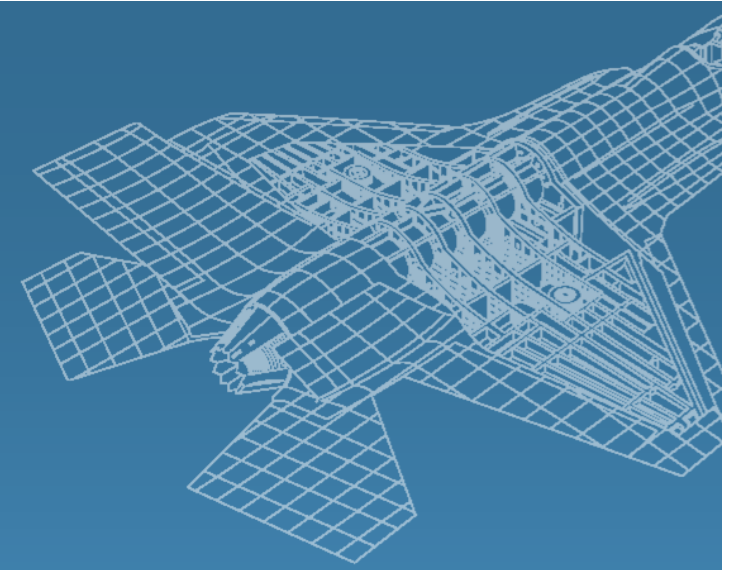

Mission-Critical Supplier in Growing Markets

Able to supply over 90% of structural / rotating aero-engine parts

Stability underpinned by ~70% of aerospace revenue under long-term agreement, with strong engine spares demand

Increased content on next-generation platforms

Howmet Aerospace: Key Takeaways

- Aerospace Revenue growth above aircraft build rates
- EBIT/EBITDA margins in top quartile of Aerospace peer set
- Greater than 90% Adjusted Free Cash Flow conversion
- Disciplined capital allocation strategy

Aerospace Market



Secular Tailwinds Drive Sustained Aerospace Market Growth

Passenger Miles Projected to Grow 1.8x in the Next Decade

Global Revenue Passenger Miles, In Billions¹

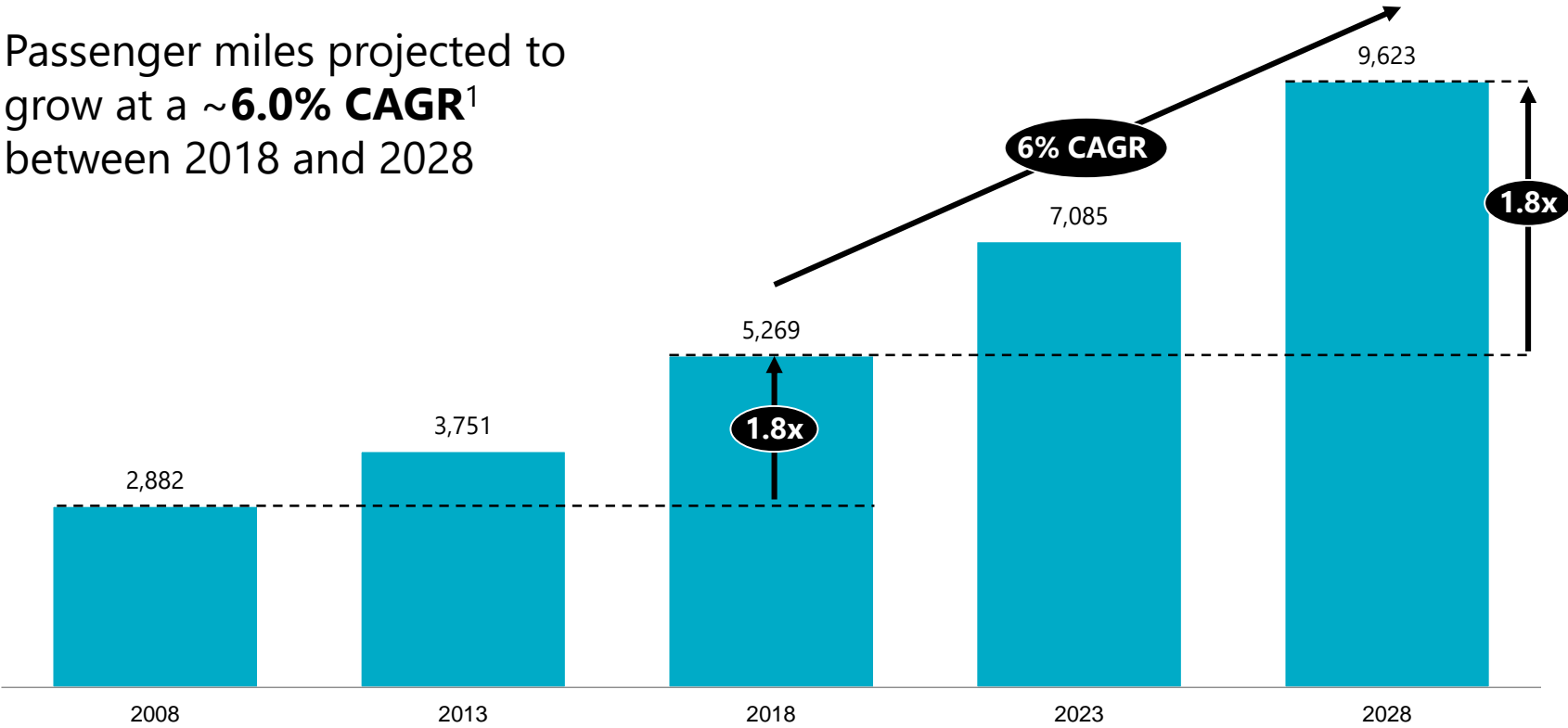

1) Airline Monitor June 2019 World Airline Traffic

Airlines Continue Expanding Their Fleets

Airlines Fleets Expected to Grow 1.6x in the Next Decade

Commercial Aircraft Fleet, In Thousands¹

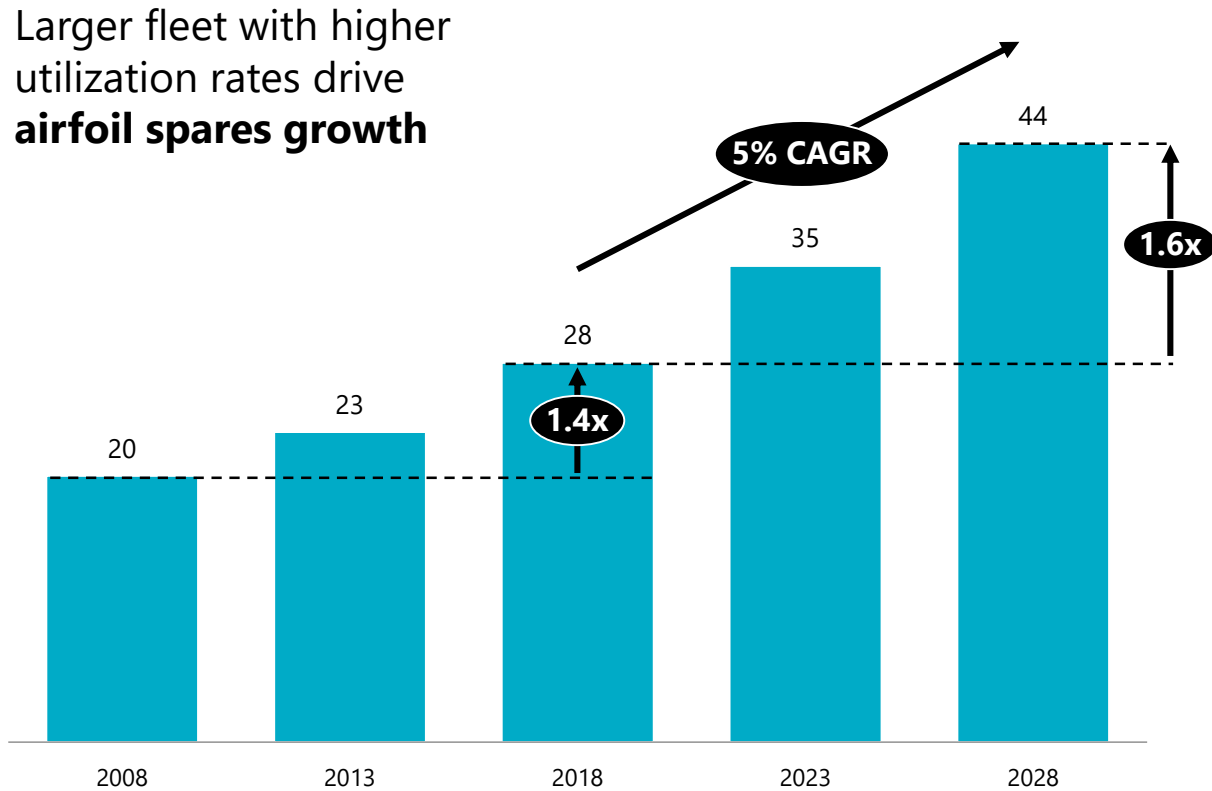

Long-Term Build Rates Are Expected to Remain Robust

Commercial Jetliner and Regional Aircraft Builds²

Over ~17,000 commercial jetliners and regional aircraft are expected to be delivered from 2020-2028

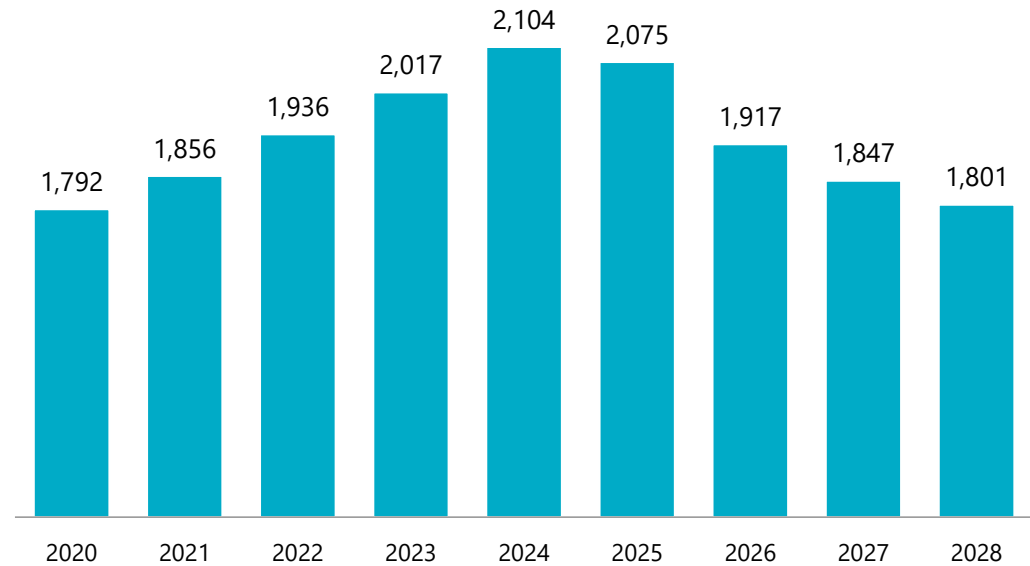

New Engines Drive Improved Fuel Consumption and Lower Environmental Footprint

The LEAP and GTF are substantially more fuel efficient than their predecessor engines. Howmet Aerospace has the know-how and proprietary intellectual property to deliver critical sub-components necessary to achieve these improvements

Fuel Consumption

Next Generation vs. Previous Generation Engines

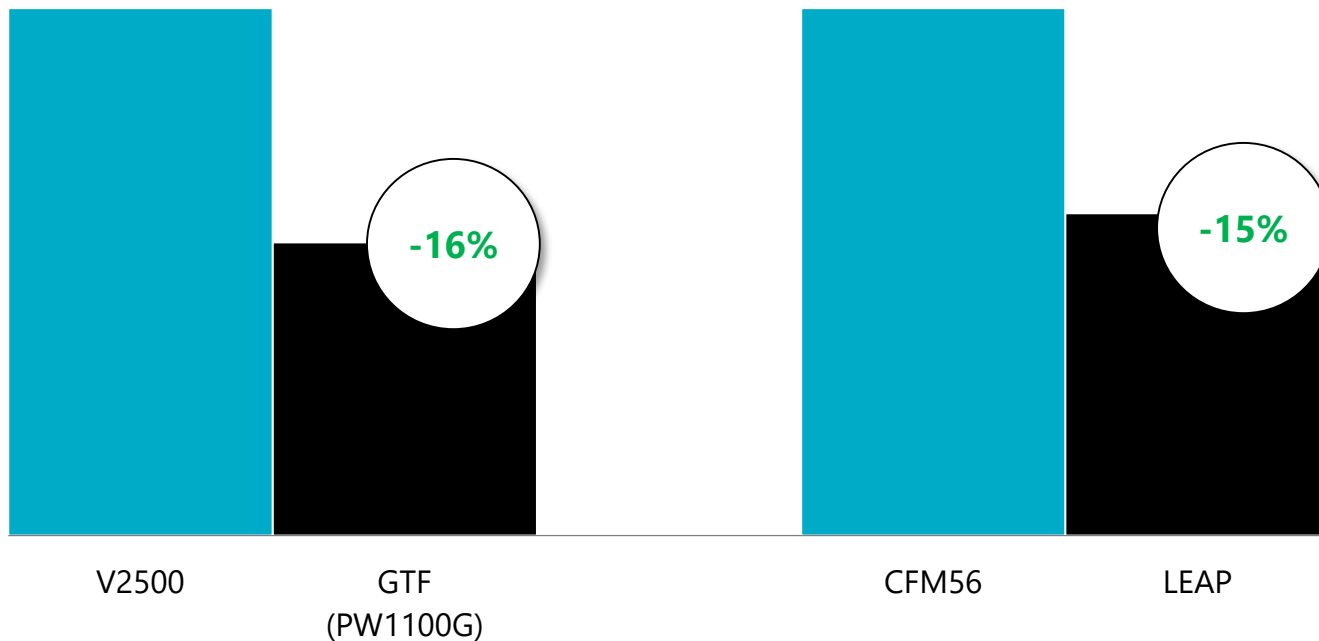

Fuel Efficiency

Higher Temperatures/Pressures

- Next generation jet engines increase efficiency by operating at higher temperatures
- Higher temperatures/pressures put greater stress on key parts such as the blades, vanes, and casings
- Howmet Aerospace's material science expertise and process know-how enable the creation of parts that can withstand the higher temperatures/pressures of the new engines

Key Aerospace Industry Trends Driving Howmet Aerospace Growth

- Large commercial aircraft order book currently at ~8 years¹
- Commercial air traffic projected to grow at ~6% CAGR over the next decade
- New engines deliver improved fuel efficiency and lower environmental footprint
- Commercial aircraft installed base projected to grow ~57% over the next decade
- Legacy-generation engine spares demand projected to peak ~2025

Howmet Aerospace



Four Segments with Over 70% of Revenue from Aerospace End Market

Leading Global Provider of Advanced Engineered Solutions

Engine Products	Fastening Systems	Engineered Structures	Forged Wheels
 <p data-bbox="336 502 479 574">~\$3.3B 2019 Revenue</p> <p data-bbox="219 645 596 759"><i>Global leader in jet engine components and seamless rolled rings</i></p> <div data-bbox="142 796 682 1016"> <p data-bbox="173 796 275 873">#1 Aerospace Airfoils Market Position</p> <p data-bbox="361 796 463 1016">#2 Aerospace Investment Casting Market Position</p> <p data-bbox="540 796 642 873">#1 Seamless Rolled Rings Market Position</p> </div> <p data-bbox="275 1082 540 1116"><u>Select Customers</u></p> 	 <p data-bbox="922 502 1065 574">~\$1.5B 2019 Revenue</p> <p data-bbox="800 682 1187 716"><i>Global leader in fasteners</i></p> <div data-bbox="774 796 1217 1045"> <p data-bbox="810 796 912 873">#1 Aerospace Fasteners Market Position</p> <p data-bbox="1075 796 1177 1045">#1 North America Truck & Trailer Industrial Fasteners Market Position</p> </div> <p data-bbox="861 1082 1126 1116"><u>Select Customers</u></p> 	 <p data-bbox="1508 502 1651 574">~\$1.3B¹ 2019 Revenue</p> <p data-bbox="1381 668 1778 739"><i>Global leader in aerospace US defense structures</i></p> <div data-bbox="1508 796 1635 873">#1 Aerospace US Defense Structures</div> <p data-bbox="1447 1082 1712 1116"><u>Select Customers</u></p> 	 <p data-bbox="2109 502 2252 574">~\$1.0B 2019 Revenue</p> <p data-bbox="1982 645 2379 759"><i>Global leader in forged aluminum commercial vehicle wheels</i></p> <div data-bbox="2109 796 2237 873">#1 Global Forged Aluminum Wheels</div> <p data-bbox="2043 1082 2308 1116"><u>Select Customers</u></p> 

1) Includes 2019 revenue associated with Savannah Disks facility previously classified in Engine Products

Market Leader in Investment Castings, Fasteners, Rings, and Forgings

Howmet Aerospace is a multi-material business with the vast majority of its products made from Superalloys and Titanium

2019 Revenue by Segment

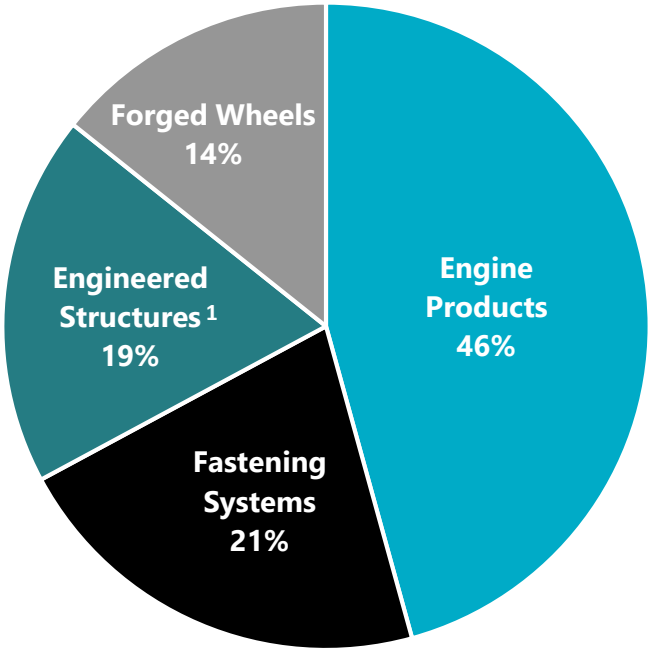

2019 Material Type

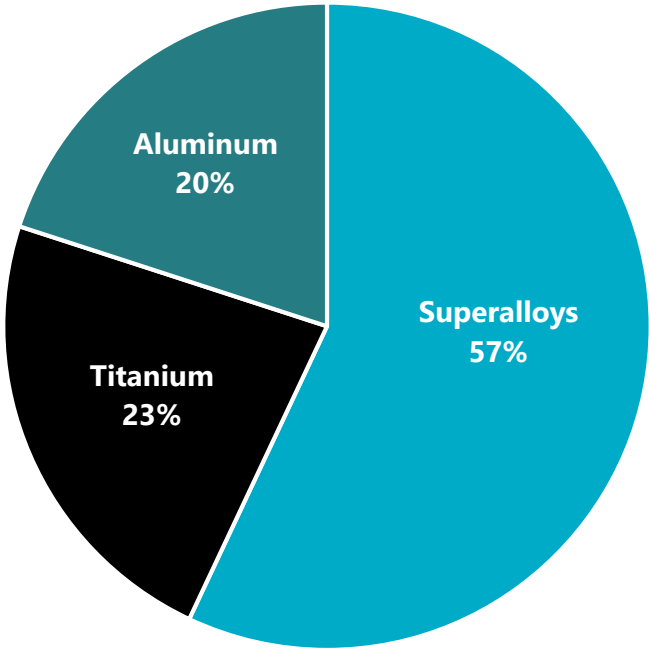

¹) Includes 2019 revenue associated with Savannah Disks facility previously classified in Engine Products

Differentiated Technology Driving Best-in-Class Capabilities in Jet Engines

Key Howmet Aerospace Engine Content

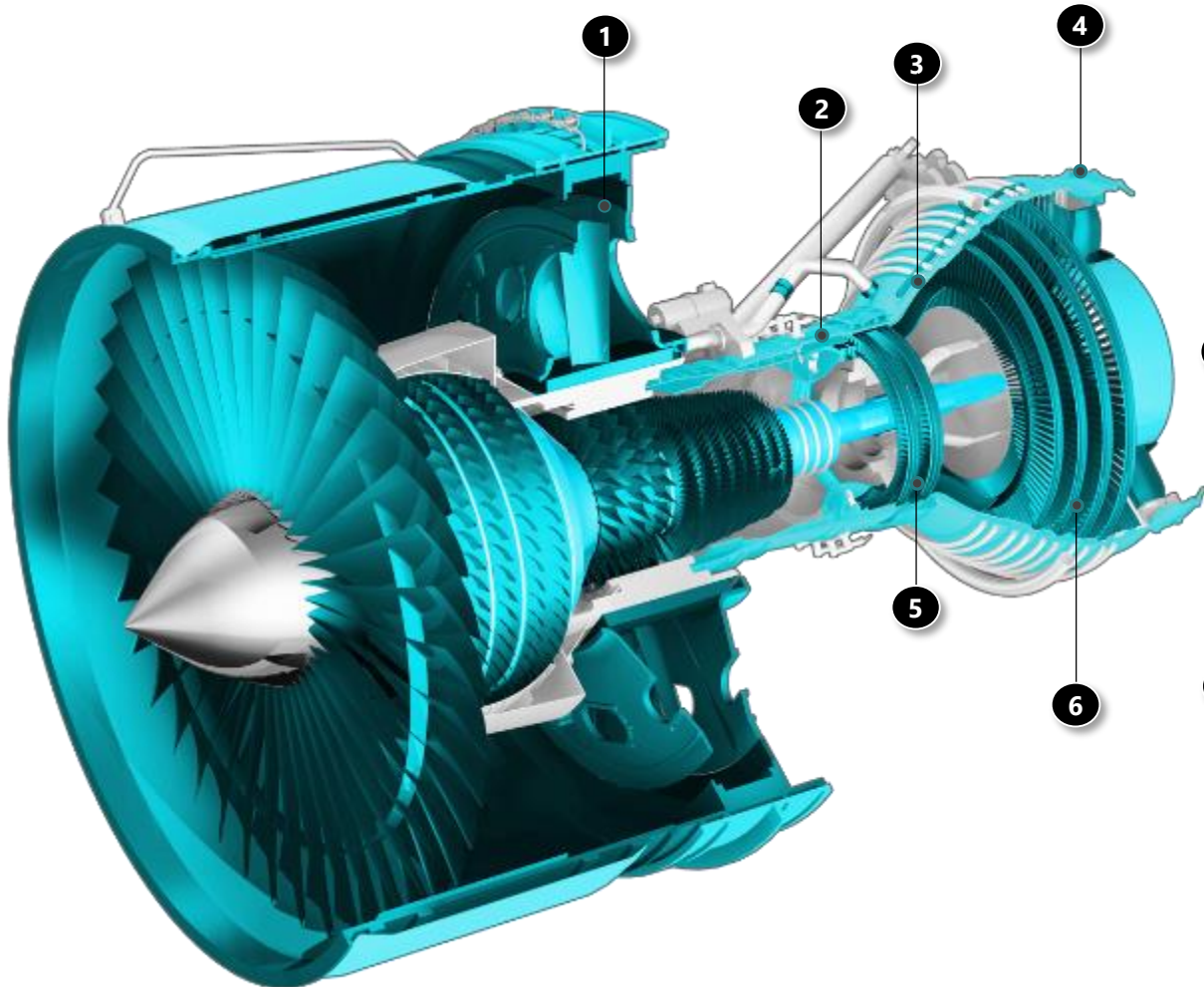

1 Front Frame (Ti), Variable Bleed Valve Door (Al)



2 Inner Diffuser, TOBI (Ni Superalloy)

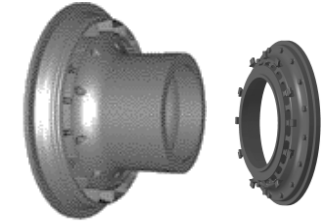

3 Mid Turbine Frame (Ni Superalloy)



4 Turbine Rear Frame (Ni Superalloy)



5 High-Pressure / Intermediate-Pressure Turbine Airfoils (Ni Superalloy), Single Crystal (SC)



6 Low-Pressure Turbine Airfoils (Ni Superalloy), Directionally Solidified (DS) / Equiax (EQ)



Howmet Aerospace is the Sole Provider for Highest Temperature Engines in JSF

Joint Strike Fighter's F135
Turbine Inlet Temperature

~3,600°F¹



Modern Commercial Jet
Turbine Inlet Temperature

~2,500°F²



FUTURE TECHNOLOGY FLOW

Engine Products: Technology to Support Growth on Next-Generation Engine Programs

Innovative Cooling

- Multi-wall cooling directs air to critical areas
- Thin trailing edge exits reduce cooling air
- Wall contouring enhances performance
- Core chemistry and processes optimized for complex airfoils

Advanced Casting and Coatings

- Nickel compressor blades for higher temperature / pressure
- Thin trailing edge nickel low-pressure blades
- Low platinum, high temperature bond coats
- Multi-chemistry thermal barrier coatings for higher temperatures

Rapid New Product Introduction

- Additive manufacturing for prototyping
- Rapid tooling for cores and patterns
- Process modeling to reduce development cycle
- All digital systems

Multi-wall Cooling Airfoil Design Cross Section Patent Drawing

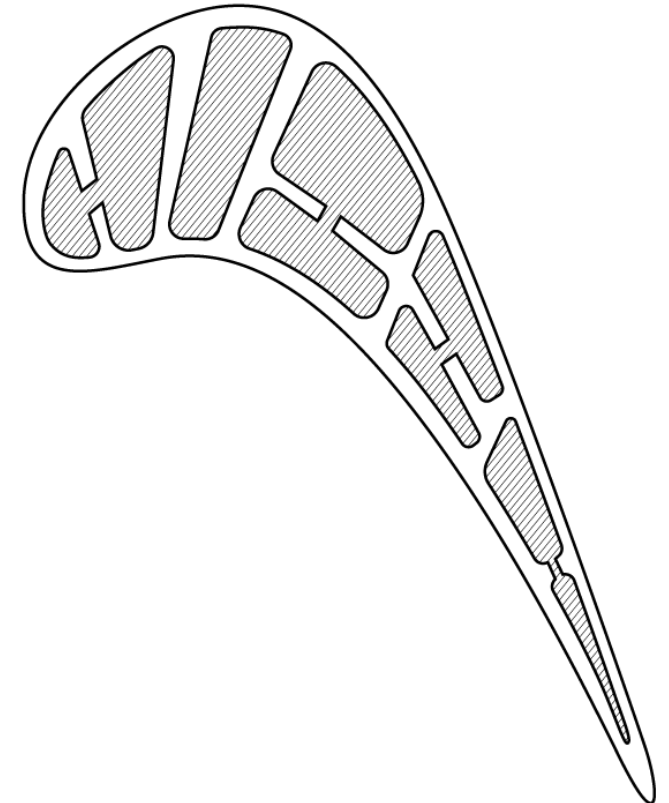

Advanced designs and techniques in conjunction with high rate production and high yields drive significant competitive advantage

Fasteners: Move to Composite Aircraft Driving Higher Value Capture

Howmet Aerospace Fasteners are Industry Leading

Patented and proprietary aerospace products to solve customer and industry challenges

- Advanced materials (composites)
- Automated assembly
- Delamination
- Multi-material joining

~80% of Fasteners used in Aerospace applications

Revenue per Shipset – Metallic Plane vs. Composite Plane

3x

2x

Fastener revenue and profit is significantly higher on composite aircraft

Carbon Fiber Content on Aircraft Increasing¹

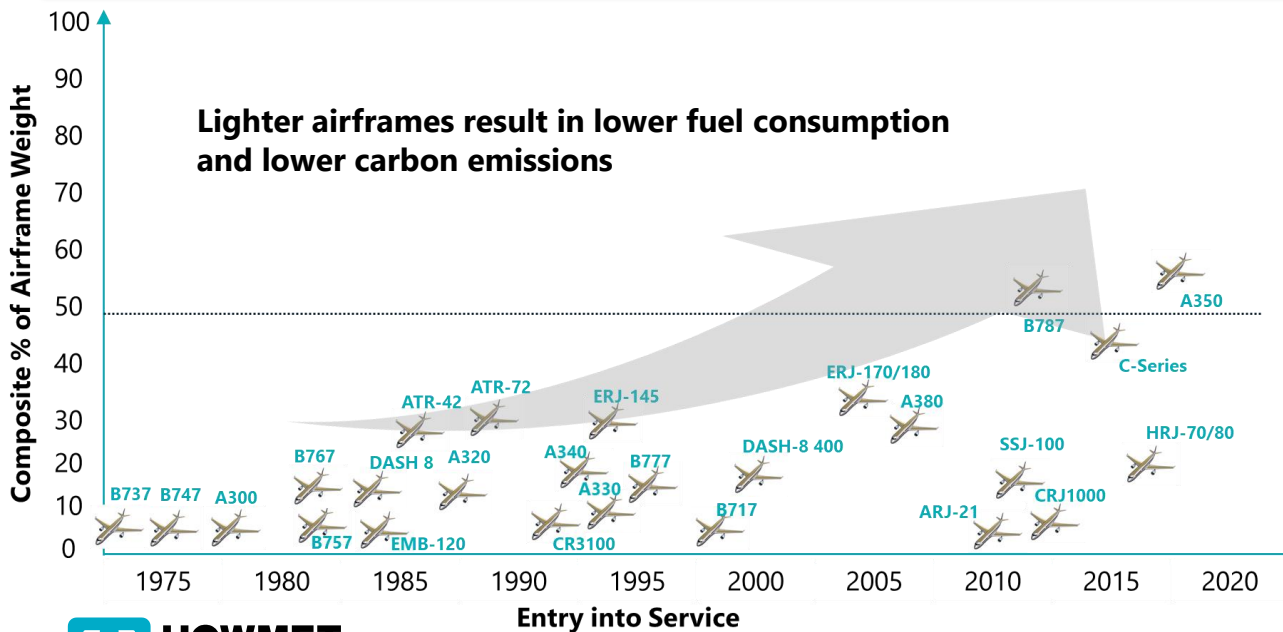

1) Composites World.

767 vs. 787
BOEING

A330 vs A350
AIRBUS

Proprietary Designs Offer Safety and Efficiency Gains

Flite-Tite® Fasteners Help Make Composite Aircraft Possible

With composite materials, come technological challenges:



Lightning strike

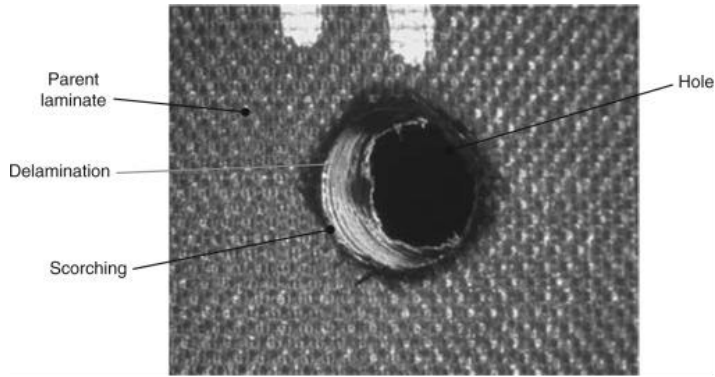

Delamination during installation

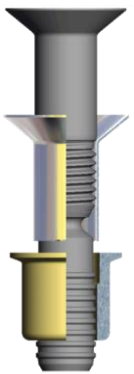

Flite-Tite® sleeve expands into composite to create a tight fit and conduct current through the structure **protecting the plane from lightning strikes**

Automation



From **LABOR INTENSIVE** two-sided assembly

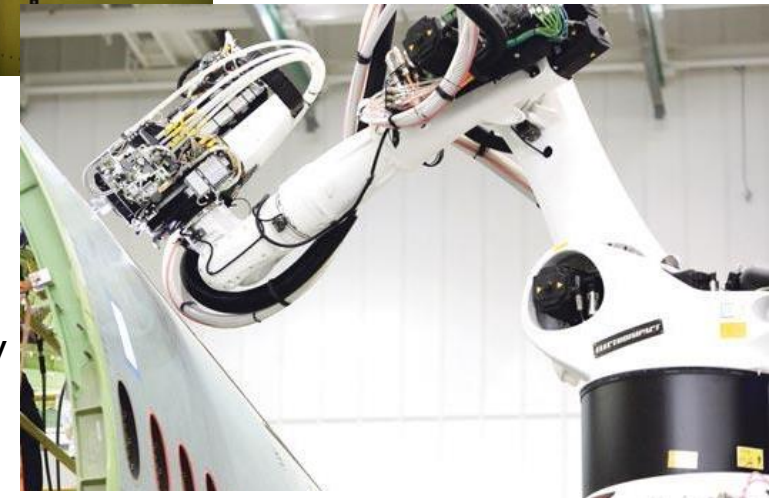

To **AUTOMATED** one-sided assembly

Integrated **Ergo-Tech® -2 Installation Tool**
Sensor-based installation tool with data acquisition enables installation process monitoring

Engineered Structures: Global leader in Aerospace and US Defense Structures

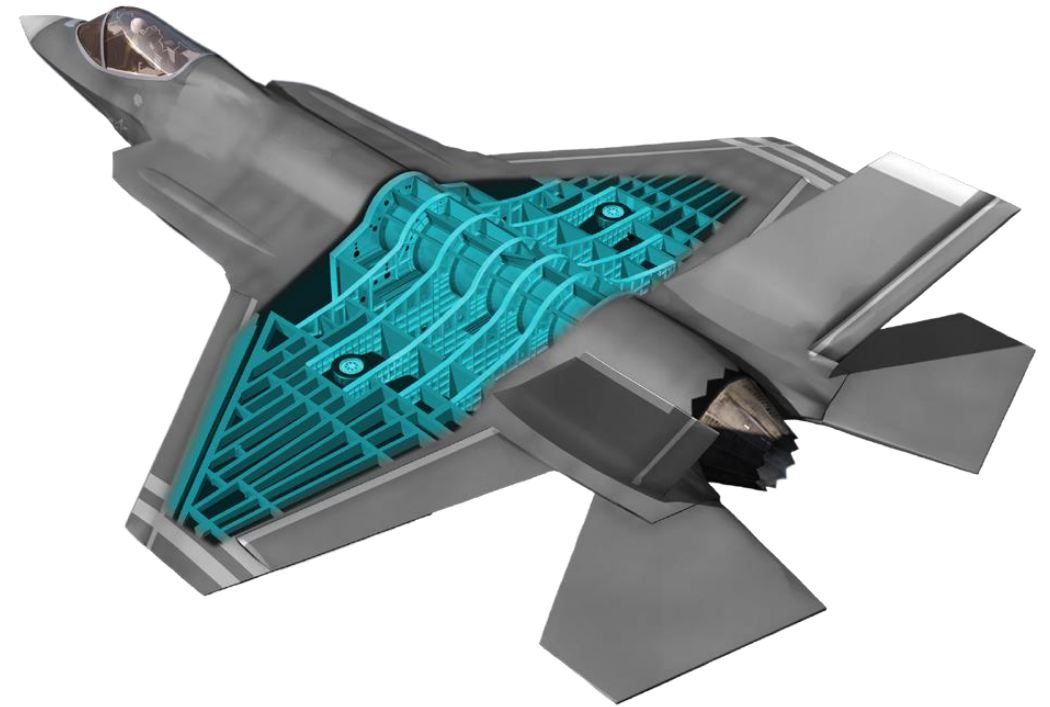

JSF Titanium and Aluminum Bulkheads
Howmet Aerospace Sole-Source Product

ESG: Proprietary Technologies Drive Efficiency; Reduce Growing Air Traffic Environmental Impacts

Growing global air passenger miles continue to drive an increase in jet fuel consumption and carbon emissions



Advanced technologies:

- Patented airfoils with advanced cooling for extreme temperature applications
- Specially-designed fasteners for lightweight composite airframe construction
- Titanium structural parts

Aircraft manufacturers and airlines are able to serve growing demand while mitigating environmental impact

Lower Fuel Use

Improved Emissions

Smaller Carbon Footprint

Forged Wheels: Differentiated Products Providing Fuel and Weight Savings

Proprietary Technology & Leading Brands

- Differentiated technology provides strength and weight savings
 - **5x stronger than steel** and **47% lighter** with patented alloy
 - Up to **1,400 lbs of weight savings** from retrofitting an 18-wheeler from steel to aluminum.
 - **10x better corrosion resistance** reduces maintenance costs
 - Vehicle owner/operator **payback ~2 years**
 - **Higher truck resale value**
- Continue to penetrate steel wheel market base
 - Aluminum wheels represent **less than 20%** of global heavy duty truck market

Strongest and Lightest Portfolio with Premium Finishes



Ultra ONE® with MagnaForce® alloy



Aircraft Wheel Forgings
Proprietary alloys

Diversified Customer Base



DAIMLER



February 2020 Launch of Lightest Heavy Duty Truck Wheel

Alcoa® Ultra ONE®



**Weight
reduced to
39 lbs.**

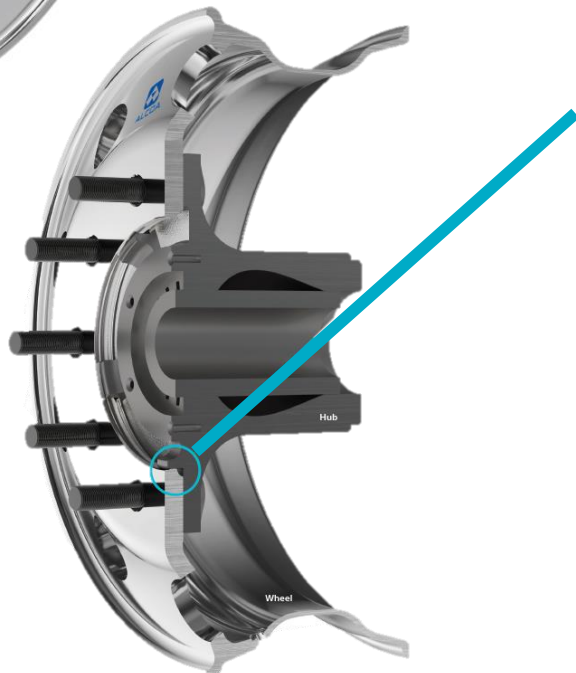

New Wheel Brings Efficiency to New Levels

- Industry-leading lightweight wheel portfolio enhanced by new Alcoa® Ultra ONE® 39 lbs. aluminum heavy duty truck wheel
- Available at all major truck OEMs
- Improved functionality with new patent-pending Alcoa Wheels Hub Bore Technology

New Hub Bore Technology Reduces Corrosion and Total Costs

- Reduces the hub-to-wheel contact area by up to 64% versus other aluminum wheels on the market
- Leaves less surface area for corrosion to form
- Less corrosion means:
 - Faster, easier and safer wheel removal encouraging time savings and enhanced technician work environments
 - Increased productivity and overall job efficiency
 - Lowered total cost of ownership

Increasing Aircraft Fleet & Spares Demand



Aircraft Installed Base¹ Expected to Grow Rapidly Over Next Decade

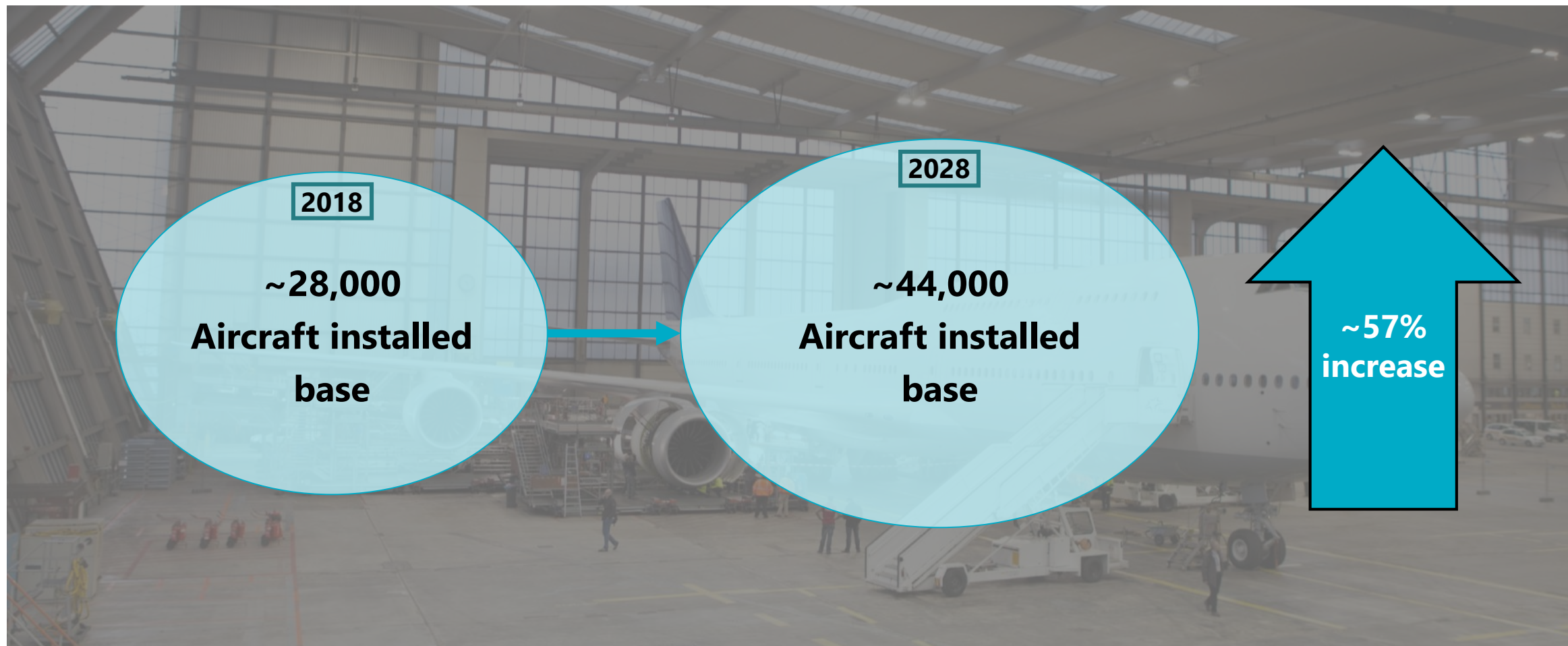

Substantial Aerospace Engines Spares Opportunity on Legacy Platforms

Large Percentages of the CFM Fleet Yet to be Serviced

Projected CFM56 shop visits annually

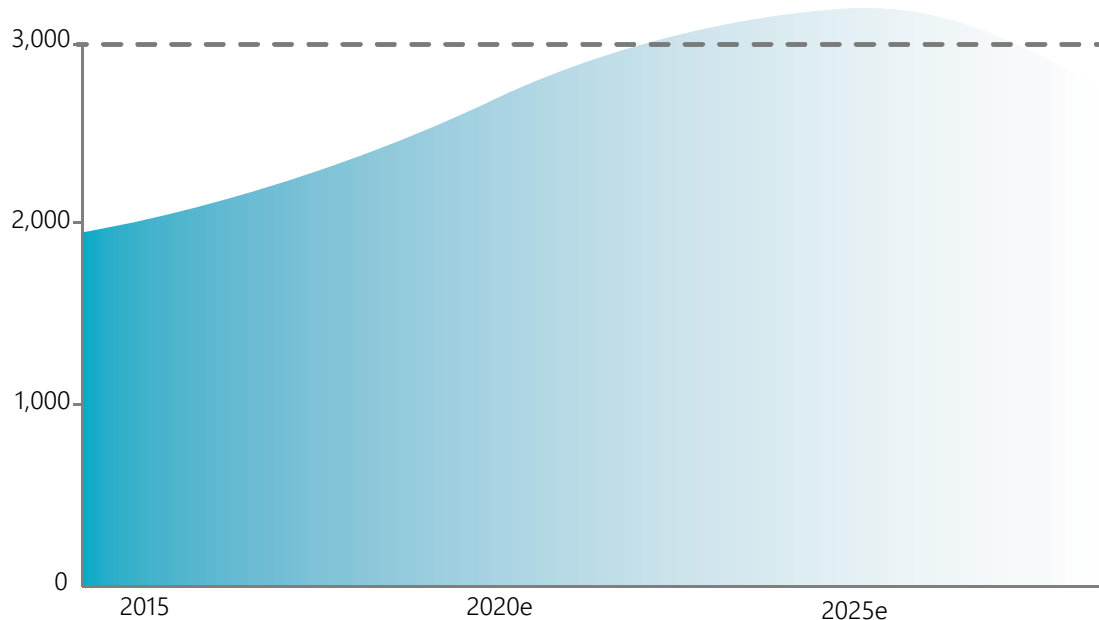

In 2018, 60% of CFM56 -5B/-7B engines had no shop visits completed, implying a significant number of shop visits to occur in the near future

Spares Trends

- Widely installed engines expected to have significant ongoing spares potential
- Wave of next gen platform introductions expected to drive significant increase in maintenance / servicing needs
- Predictable engine and aircraft maintenance schedules / requirements expected to drive stable spares growth

Many of Howmet Aerospace's products are Limited Life Parts (LLPs) that require replacement after a certain number of flight hours

Growth and Utilization of Commercial Aircraft Engine Fleet Will Drive Spares

~95K Commercial Engines In Service Within Next 10 Years ...

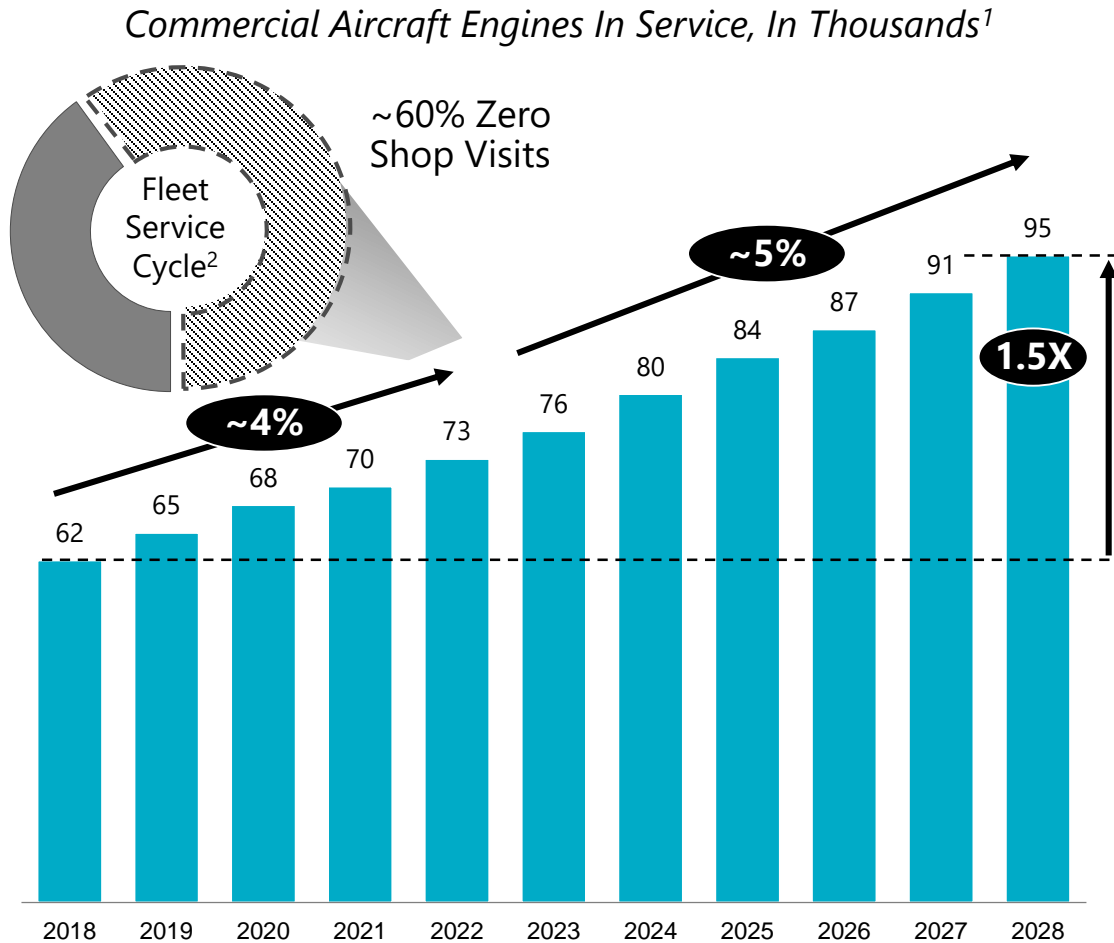

...Leading to Strong OEM Spare Part Outlook

- Fleet OEM's shop visit forecast ~5% - 7% CAGR
- Increased utilization in harsh environments
- Service cycle accelerating as fleet matures

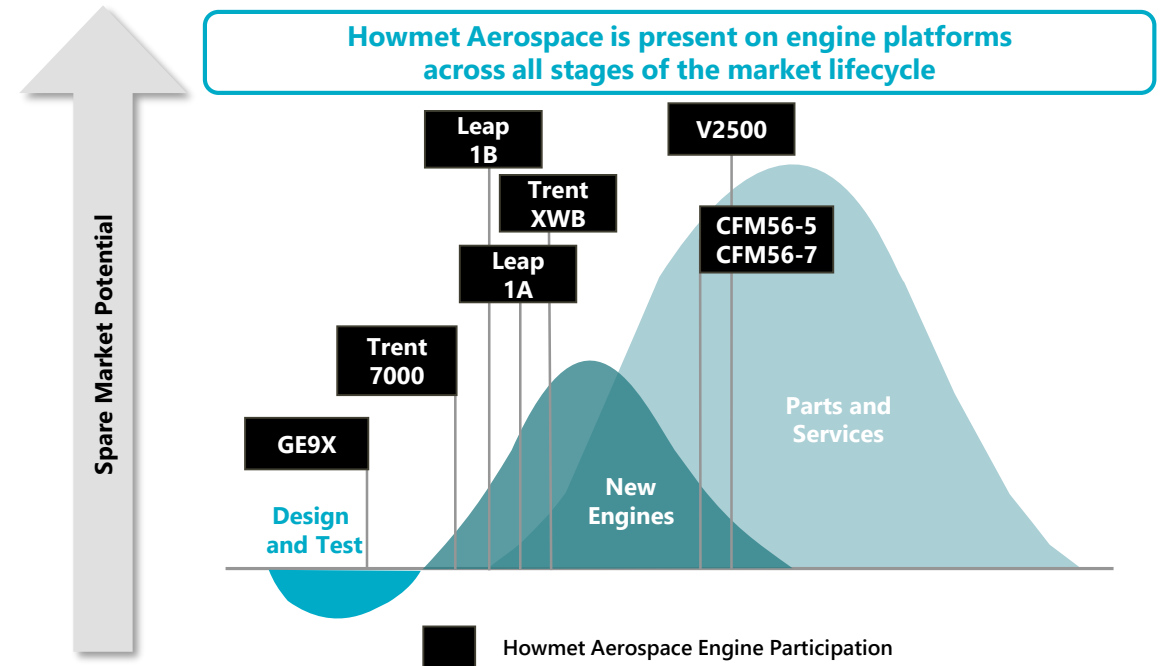

Source: Fairmont Consulting Group

Airfoil Spares, Favorable Pricing and Strategic Investments Will Drive Growth in 2020

Spares Business Critical to Howmet Aerospace

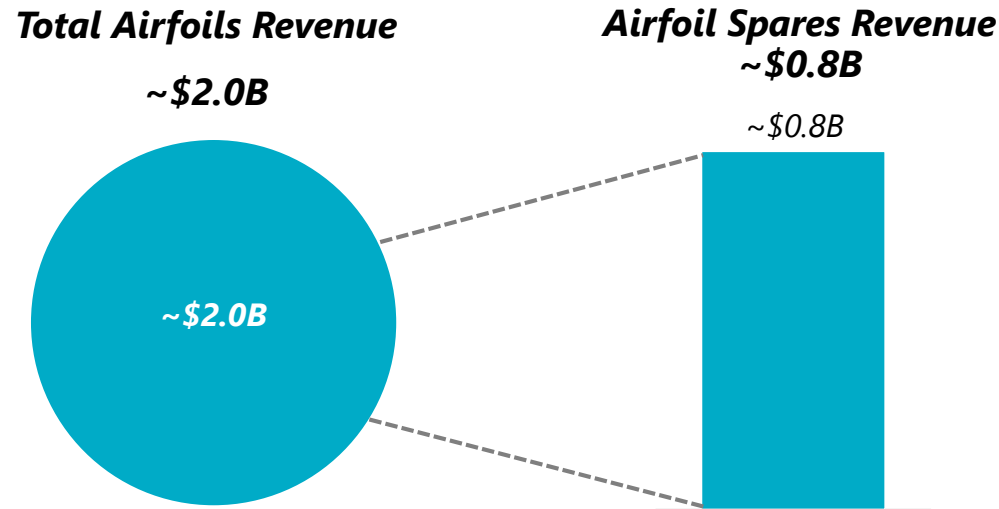

**Spares represent ~40% of the
~\$2.0B airfoils business**

Market Dynamics Favor Howmet Aerospace

- Performance requires increasing engine temperatures
 - Designs increasing in complexity
 - Operating in harsh environments
 - Higher temperatures/pressures
- Drives additional demand and buffering
 - Spare engines and retrofits
 - Increased shop visits with early replacement
 - MRO spending rising in air traffic and load factors, coupled with older fleets continuing to fly¹
- Howmet Aerospace invested
 - Technology for next generation engines
 - Production capacity
- Opportunity to capture share
- Favorable conditions for pricing

Revenue Shipset Growth on Next-Generation Engine Platforms up 80% - 100%

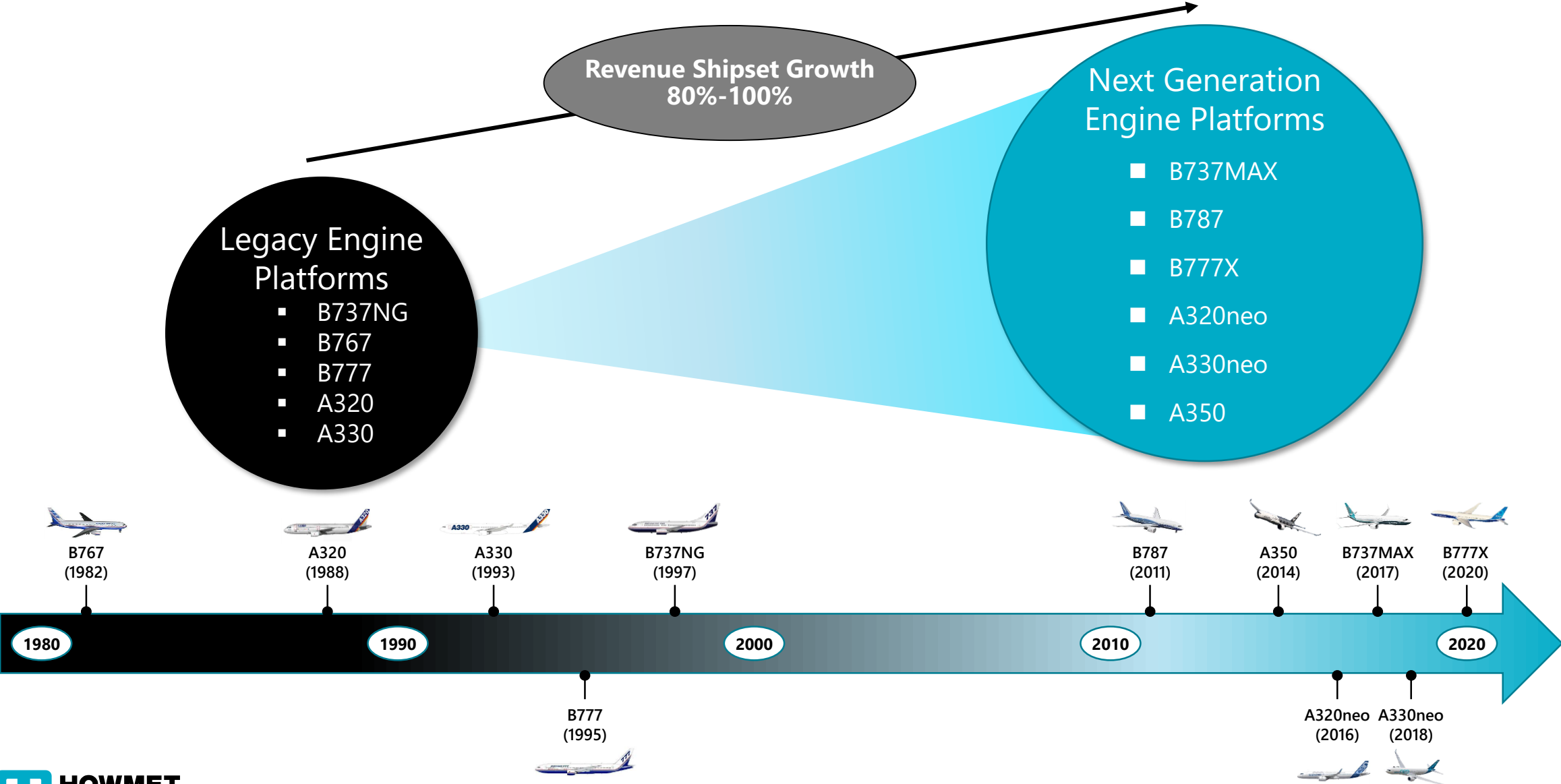

Note: Year represents date of first delivery, based on Airline Monitor June 2019 Aircraft Forecast.

Financial



Howmet Aerospace¹ Year-over-Year Progression

	FY 2018	FY 2019 (YoY)
Total Revenue	\$6,798M	\$7,105M , up 5% <i>(up 6% organically)</i>
Segment Operating Profit	\$1,105M	\$1,390M , up 26%
Segment Operating Profit Margin	16.3%	19.6% , up 330 bps
Capital Expenditures	\$407M	\$344M , down 15%
Capital Expenditures as a % of Revenue	6%	5%

¹All metrics exclude Howmet Aerospace Corporate Costs
2019 estimated annual Howmet Aerospace Corporate Costs of ~\$100M

Howmet Aerospace¹ 2019 vs 2018 Year-over-Year Progression

	1Q19 vs 1Q18	2Q19 vs 2Q18	3Q19 vs 3Q18	4Q19 vs 4Q18
Segment Operating Profit	Up 20%	Up 23%	Up 28%	Up 32%
Segment Operating Profit Margin	+210 bps	+300 bps	+330 bps	+480 bps

¹All metrics exclude Howmet Aerospace Corporate Costs
2019 estimated annual Howmet Aerospace Corporate Costs of ~\$100M

Operating Model

Focused Growth

- Leading positions in growing markets with **material science, process technology and quality**
- Aero Engines: Increased need for **higher engine temperatures and pressures** to improve fuel economy and reduce emissions
- Aero Fasteners and Structures: Increased **adoption of carbon fiber airframes** increases demand for our Fasteners and lightweight Titanium Structures
- Forged Wheels: Opportunity to **penetrate global commercial transportation steel wheels market** (~80% Share) with Aluminum wheels, which improve fuel economy and increase payload capacity

Price Increase and Cost Reduction

Price Increases

- Long term agreements (**LTAs**) **reviewed by CEO**
- Price increase driven by **differentiated products**
- **2019 price increases of ~\$78M**
- 2020-2023 LTAs under review

Cost Reduction

- **Disciplined approach** to manufacturing
- Strict focus on **cost reduction**
- Maximize **revert utilization**
- Benchmark **corporate costs** by function
- **Cost Reduction ~\$110M in 2019; Run Rate reduction of ~\$160M**

Asset Utilization

- Improvement in critical asset utilization with **minimal capital investment**
- Baseline: **168 hours** of weekly available machine time
- Analysis: **historical trends and forecast** mapped by month
- **Latent capacity** results in reduced demand for capital investment

Focused and
Template-driven
Quarterly Review
Process

Capital Expenditures: Targeting ~25% Reduction from 2018 to ~4% of Revenue in 2020

- Asset Review prior to Capital request
 - Equipment & plant-level asset utilization must be near peak before new capital expenditures are considered
 - 2019 emphasis on Overall Equipment Effectiveness (OEE) revealed untapped capacity to grow volume without significant capital spend
- Investment Case
 - Target IRR well in excess of cost of capital
 - Emphasis placed on payback period to avoid projects with returns driven by hard to predict terminal value
- CEO Review
 - Capital allocation is a core responsibility of the CEO and CFO
 - All capital spending above \$0.5M is reviewed by the CEO and CFO

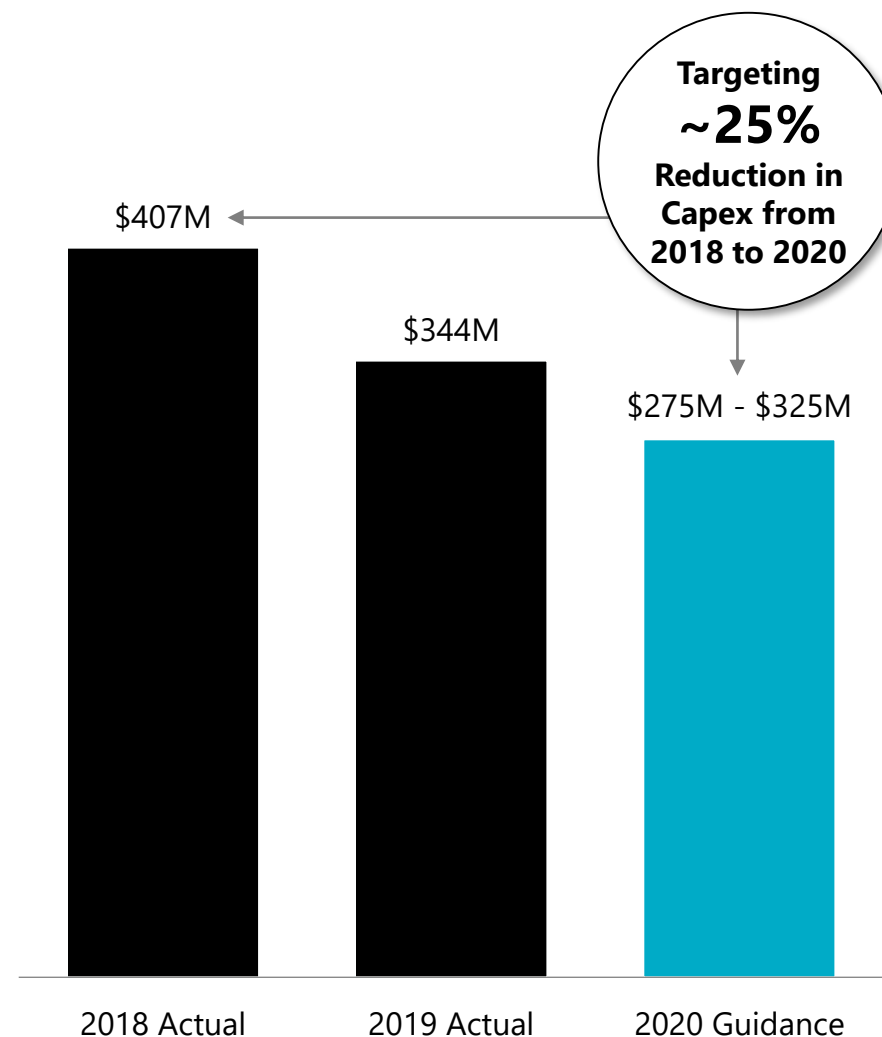

Expanded Capacity for Aerospace Airfoils, Rings and Forged Wheels

Major Capital Spending

		TOTAL SPEND
Engine Products	Whitehall, Dover, Dives casting furnaces	~\$300M
	Whitehall & Morristown airfoil capacity	
	Rancho Cucamonga rings press	
Forged Wheels	Hungary wheels expansion	~\$130M
TOTAL		~\$430M

Future capital requirements expected to decline to ~4% of revenue

Strong Operational Performance Compared to Peers

Howmet Aerospace compares favorably vs. peers across growth, profitability, and FCF generation metrics

Historical Sales Growth (2016 – 2018)

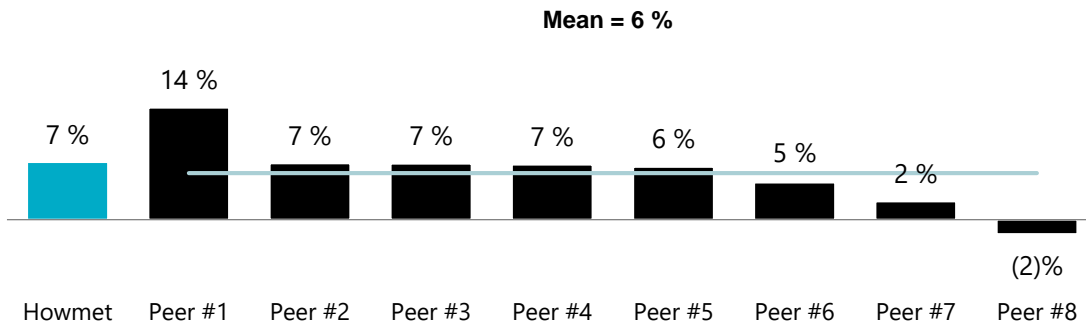

Net Debt / LTM Adj. EBITDA¹

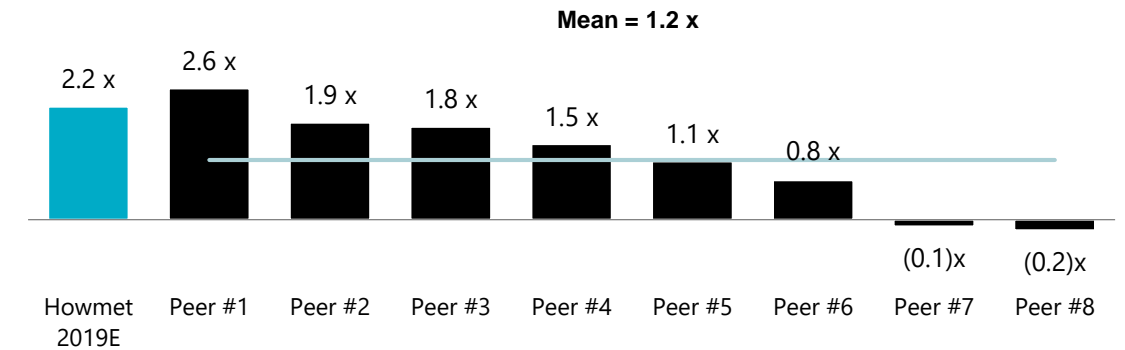

2019 Adj. EBITDA Margins²

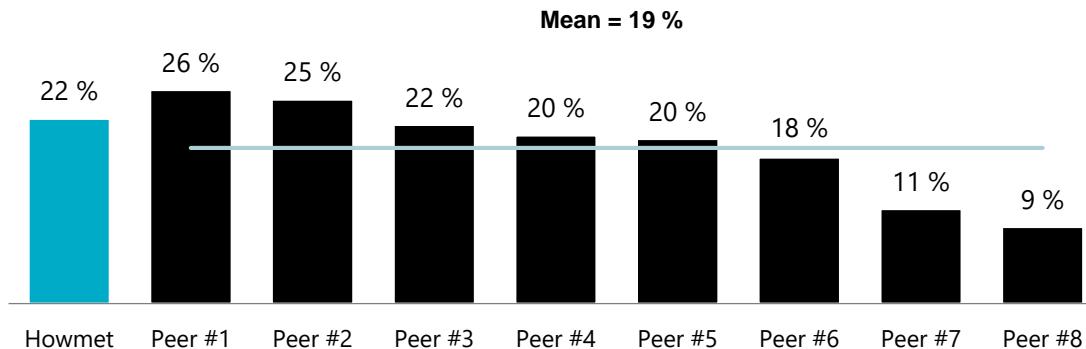

Free Cash Flow / Net Income Conversion³

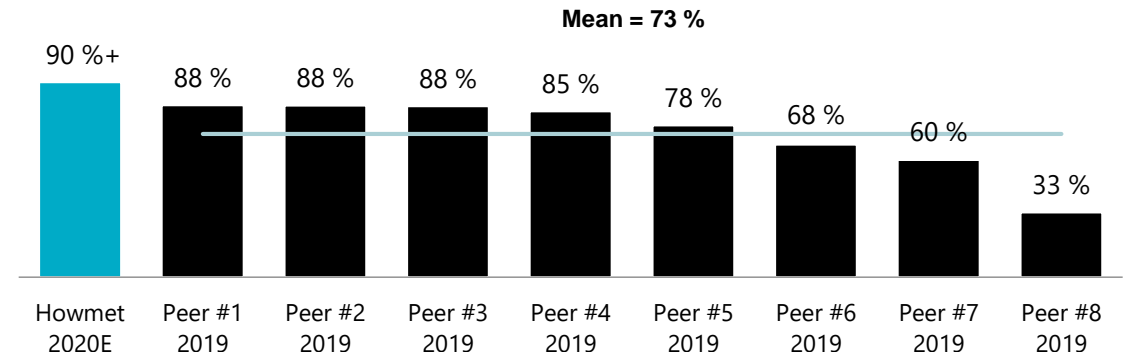

Source: Company, IBES median estimates, Bloomberg; market data as of 14-Feb-2020; Peer figures per Wall Street Research median estimates excluding acquisitions
 Note: Adj. EBITDA excludes special items and includes an allocation of corporate costs; Peers include Allegheny Technologies Inc., Hexcel Corporation, Meggitt PLC, MTU Aero Engines AG, RBC Bearings Incorporated, Roll-Royce Holdings plc, Safran SA, Woodward, Inc.

1) Howmet Aerospace net leverage defined as 2019 pro forma net debt / 2019 Adj. EBITDA including estimated Howmet Aerospace corporate costs of ~\$100M. Peer leverage defined as unadj. net debt / LTM Adj. EBITDA per latest qtrly filings 2) Includes estimated Howmet Aerospace corporate costs of ~\$100M 3) Represents Howmet Aerospace 2020E Adj. Free Cash Flow / Net Income excluding special items Conversion.
 See appendix for reconciliations



Howmet Aerospace: Pro Forma Capital Structure as of 12/31/2019

\$M	Arconic Inc	Arconic Corp	Howmet Aerospace
Cash ¹	\$1,703	\$400	\$1,303
Gross Debt	\$5,940	\$1,200	\$4,740
Net Debt	\$4,237	\$800	\$3,437
Net-Debt-to-LTM EBITDA ²	1.8x	N/A	~2.2x ³

Financial Position

- 2020 Free Cash Flow Conversion greater than 90%
- Ample liquidity with \$1.5B Five-Year Revolver
- Active management of pension plan exposure
- Separation does not trigger incremental cash contribution to pension plans

Financial Stewardship

- Capital investment in business largely complete
- Focused on improving operational efficiency (OEE) to drive organic growth
- Minimal legacy environmental liabilities
- Reduce debt by ~\$1.3B in 2020

2020 Guidance Assumptions

	2Q – 4Q 2020 Assumptions	FY 2020 Assumptions	Comments
Capex	\$200M - \$250M	\$275M - \$325M	<ul style="list-style-type: none"> Excludes separation capex of ~\$10M expected in 2020
Pension Cash Contributions & OPEB Payments	\$135M - \$165M	\$180M - \$220M	<ul style="list-style-type: none"> Separation does not trigger incremental pension cash contributions
Pension / OPEB-related Expense	~\$35M Total (~\$30M Non-Service)	~\$45M Total (~\$35M Non-Service)	
Post-Tax Unfunded Pension / OPEB-related Liability	~\$820M Pension Liability ~\$170M OPEB Liability		<ul style="list-style-type: none"> As of 12/31/2019 Applied U.S. federal corporate tax rate of 21% to figures
Tax Rate	Operational tax %= 28.0% - 30.0% Cash tax %= ~10%		
Depreciation & Amortization	\$200M - \$230M	\$265M - \$305M	
Diluted Share Count	~440M		<ul style="list-style-type: none"> Excludes the impact of potential share repurchases

Capital Allocation Priorities and Guidance

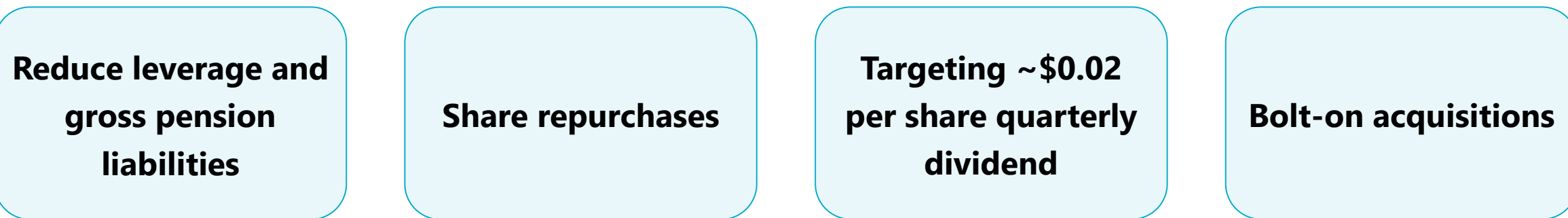

2020 Guidance

	Revenue	EPS ex. Special Items	Adj. Free Cash Flow
2Q – 4Q 2020	\$5.2B – 5.4B	\$1.20 – \$1.28	\$775M – \$825M
Full Year 2020	\$6.8B – 7.0B <i>Organic Revenue Growth: 1% - 3%</i>	\$1.54 – \$1.64	\$675M – \$725M FY20 Adj. FCF conversion greater than 90% ¹

Howmet Aerospace Management Team



John Plant, Executive Chairman & Co-Chief Executive Officer, Howmet Aerospace; Current Chairman & Chief Executive Officer Arconic Inc.

- Held his role as CEO since February 2019
 - Mr. Plant has served as a director since 2016 and Chairman of the Board since 2017
 - Mr. Plant is the former Chairman of the Board, President and Chief Executive Officer of TRW Automotive, which was acquired by ZF Friedrichshafen AG in May 2015
 - Mr. Plant also serves as a director of Jabil Circuit Corporation and Masco Corporation
-



Ken Giacobbe, EVP & Chief Financial Officer

- Held his role since the company's separation from Alcoa in 2016
 - Prior to separation, Mr. Giacobbe served as CFO of Alcoa's Engineered Products and Solutions division
 - Joined Alcoa in 2004 as Vice President of Finance for Global Extruded Products
 - M.B.A. from the University of South Florida and B.S. in Economics from State University of New York at Oneonta
-



Kate Ramundo, EVP, Chief Legal Officer and Corporate Secretary

- Held her role since November 2016
 - Prior to joining Arconic, Ms. Ramundo was EVP, General Counsel and Secretary of ANN, Inc. and VP, Deputy General Counsel / Assistant Secretary of Colgate-Palmolive
 - J.D. from Columbia University School of Law and B.A. from Georgetown University
-



Neil Marchuk, EVP, Human Resources

- Held his role since February 2019
 - Prior to joining Arconic, Mr. Marchuk had been Executive Vice President and Chief Human Resources Officer at Adient
 - Mr. Marchuk previously served as EVP of Human Resources at TRW from 2004 to 2015
 - M.A. from the University of the West of Scotland and B.A. in Commerce from University of Windsor
-



Michael Chanatry, VP, Chief Commercial Officer

- Mr. Chanatry joined Arconic in 2018 as Chief Commercial Offer
- Prior to joining Arconic, Mr. Chanatry served in commercial and military market roles at General Electric and Lockheed Martin
- B.A. from Niagara University

Howmet Aerospace Management Team (continued)



Tolga Oal, Co-Chief Executive Officer-Designate, Howmet Aerospace; Acting President, Engineered Structures

- Held his role since 2019
 - Previously held leadership roles in operations and purchasing for American Axle & Manufacturing
 - Prior to American Axle & Manufacturing, Mr. Oal held key finance and operations positions in TRW Automotive's Electronics business and at Siemens VDO Automotive
 - M.B.A. in International Finance from the University of Florida and B.S. in Chemical Engineering / Process Engineering from Bosphorus University in Istanbul, Turkey
-



Dirk Bauer, President, Engine Products

- Held his role since 2016
 - Joined Alcoa in 2013 as Vice President and General Manager, Europe Aerospace Structural Castings and Airfoils
 - Prior to joining Alcoa, held roles at Siemens including President Director General for Flender Graffenstaden S.A.S. and various roles at Siemens Management Consulting
 - German Diploma Engineering Degree in Mechanical Engineering from Technical University Darmstadt with a focus on Rotating Equipment Gas Turbines, Aero Engines and Combustion
-



Vitaliy V. Rusakov, President, Fastening Systems

- Held his role since 2010
 - Previously, Mr. Rusakov served as Chief Operating Officer for Arconic Engineered Products and Solutions
 - Mr. Rusakov began his career in the fastening business in 1998
 - M.B.A. from Georgetown University and INSEAD, B.A. in International Economics from Kiev University of Economics and B.A. in Linguistics and Education from Kiev University of Linguistics
-



Merrick Murphy, President, Forged Wheels

- Held his role since 2016
 - Prior to this appointment, Mr. Murphy was Vice President and General Manager for Alcoa's Commercial Vehicle Wheel business in the Asia Pacific region
 - Mr. Murphy joined Alcoa in 1997
 - B.A. in Business Administration from Loyola University, in Chicago
-

Howmet Aerospace: Key Takeaways

- Aerospace Revenue growth above aircraft build rates
- EBIT/EBITDA margins in top quartile of Aerospace peer set
- Greater than 90% Adjusted Free Cash Flow conversion
- Disciplined capital allocation strategy

Appendix



Reconciliation of Arconic Inc Engineered Products & Forgings Segment Organic Revenue

(\$ in millions)

	Year ended December 31,	
	2018	2019
<u>Arconic Inc Engineered Products and Forgings Segment</u>		
Third-party sales	\$6,798	\$7,105
Less:		
Sales – Eger forgings	32	—
Sales – UK forgings	131	116
Aluminum price impact	n/a	(19)
Foreign currency impact	n/a	(53)
Arconic Inc Engineered Products and Forgings Segment Organic revenue	\$6,635	\$7,061

Arconic Inc Engineered Products and Forgings Segment Information

Our audited consolidated financial statements as of and for the year ended December 31, 2019 are not yet complete and are not available as of the date of this presentation. On January 27, 2020, Arconic Inc. reported unaudited financial results for the year ended December 31, 2019 for its Engineered Products and Forgings (“EP&F”) segment. Our historical consolidated financial information was prepared from Arconic Inc’s historical accounting records, including the underlying financial data derived from the operations that comprise Arconic Inc’s EP&F segment. Certain financial information of Arconic Inc’s EP&F segment included in this presentation is the information of Arconic Inc’s EP&F segment as a reportable segment of Arconic Inc. Our final audited consolidated financial statements as of and for the year ended December 31, 2019 may differ from Arconic Inc’s EP&F segment’s unaudited financial results included in this presentation, and the unaudited financial results for Arconic Inc’s EP&F segment for the year ended December 31, 2019 are not necessarily indicative of our future results for any subsequent periods.

Arconic Inc Engineered Products and Forgings Segment Organic revenue is a non-GAAP financial measure. Management believes this measure is meaningful to investors as it presents revenue on a comparable basis for all periods presented due to the impact of the sale of the forgings businesses in Eger, Hungary (divested in December 2018) and the United Kingdom (divested in December 2019), and the impact of changes in aluminum prices and foreign currency fluctuations relative to the prior year periods. The revenue from a small manufacturing facility that was divested in the second quarter of 2019 and the small energy business that was divested in the third quarter of 2019 was not material and therefore is included in Organic revenue.

Arconic Inc Calculation of Total Segment Operating Profit Margin

(\$ in millions)	1Q18	2Q18	3Q18	4Q18	2018	1Q19	2Q19	3Q19	4Q19	2019
Arconic Inc Third Party Sales – Engineered Products & Forgings	\$1,666	\$1,734	\$1,683	\$1,715	\$6,798	\$1,756	\$1,822	\$1,794	\$1,733	\$7,105
Arconic Inc Third Party Sales – Global Rolled Products	1,754	1,875	1,839	1,755	7,223	1,784	1,868	1,763	1,667	7,082
Total Arconic Inc segment sales	\$3,420	\$3,609	\$3,522	\$3,470	\$14,021	\$3,540	\$3,690	\$3,557	\$3,400	\$14,187
Total Arconic Inc segment operating profit⁽¹⁾⁽²⁾	\$401	\$433	\$391	\$361	\$1,586	\$448	\$539	\$524	\$504	\$2,015
Total Arconic Inc segment operating profit margin	11.7%	12.0%	11.1%	10.4%	11.3%	12.7%	14.6%	14.7%	14.8%	14.2%

Arconic Inc Engineered Products and Forgings Segment Information

Our audited consolidated financial statements as of and for the year ended December 31, 2019 are not yet complete and are not available as of the date of this presentation. On January 27, 2020, Arconic Inc. reported unaudited financial results for the year ended December 31, 2019 for its Engineered Products and Forgings (“EP&F”) segment. Our historical consolidated financial information was prepared from Arconic Inc’s historical accounting records, including the underlying financial data derived from the operations that comprise Arconic Inc’s EP&F segment. Certain financial information of Arconic Inc’s EP&F segment included in this presentation is the information of Arconic Inc’s EP&F segment as a reportable segment of Arconic Inc. Our final audited consolidated financial statements as of and for the year ended December 31, 2019 may differ from Arconic Inc’s EP&F segment’s unaudited financial results included in this presentation, and the unaudited financial results for Arconic Inc’s EP&F segment for the year ended December 31, 2019 are not necessarily indicative of our future results for any subsequent periods.

Segment performance is evaluated based on a number of factors; however, the primary measure of performance is Segment operating profit. Arconic Inc’s definition of Segment operating profit is Operating income excluding Special items. Special items include Restructuring and other charges. Segment operating profit includes the impact of LIFO inventory accounting, metal price lag, intersegment profit eliminations, and derivative activities.

⁽¹⁾ See Arconic Inc’s Reconciliation of Total segment operating profit to Consolidated income before income taxes.

⁽²⁾ For 2Q18, Segment operating profit for the Global Rolled Product segment included the impact of a \$23 charge related to a physical inventory adjustment at one plant.

Reconciliation of Arconic Inc Total segment operating profit to Consolidated income before income taxes

(\$ in millions)	1Q18	2Q18	3Q18	4Q18	2018	1Q19	2Q19	3Q19	4Q19	2019
Arconic Inc Total segment operating profit	\$401	\$433	\$391	\$361	\$1,586	\$448	\$539	\$524	\$504	\$2,015
Unallocated amounts:										
Restructuring and other charges	(7)	(15)	2	11	(9)	(12)	(499)	(119)	10	(620)
Corporate expense	(61)	(94)	(48)	(49)	(252)	(62)	(121)	(79)	(98)	(360)
Arconic Inc Consolidated operating income (loss)	333	324	345	323	1,325	374	(81)	326	416	1,035
Interest expense	(114)	(89)	(88)	(87)	(378)	(85)	(85)	(86)	(82)	(338)
Other expense, net	(20)	(41)	(8)	(10)	(79)	(32)	(29)	(31)	(30)	(122)
Arconic Inc Consolidated income (loss) before income taxes	\$199	\$194	\$249	\$226	\$868	\$257	\$(195)	\$209	\$304	\$575

Arconic Inc Engineered Products and Forgings Segment Information

Our audited consolidated financial statements as of and for the year ended December 31, 2019 are not yet complete and are not available as of the date of this presentation. On January 27, 2020, Arconic Inc. reported unaudited financial results for the year ended December 31, 2019 for its Engineered Products and Forgings (“EP&F”) segment. Our historical consolidated financial information was prepared from Arconic Inc’s historical accounting records, including the underlying financial data derived from the operations that comprise Arconic Inc’s EP&F segment. Certain financial information of Arconic Inc’s EP&F segment included in this presentation is the information of Arconic Inc’s EP&F segment as a reportable segment of Arconic Inc. Our final audited consolidated financial statements as of and for the year ended December 31, 2019 may differ from Arconic Inc’s EP&F segment’s unaudited financial results included in this presentation, and the unaudited financial results for Arconic Inc’s EP&F segment for the year ended December 31, 2019 are not necessarily indicative of our future results for any subsequent periods.

Segment performance is evaluated based on a number of factors; however, the primary measure of performance is Segment operating profit. Arconic Inc’s definition of Segment operating profit is Operating income excluding Special items. Special items include Restructuring and other charges. Segment operating profit includes the impact of LIFO inventory accounting, metal price lag, intersegment profit eliminations, and derivative activities.

Reconciliation of Arconic Inc Corporate Expense Excluding Special Items

(\$ in millions)	4Q18	2018	1Q19	2Q19	3Q19	4Q19	2019
Arconic Inc Corporate expense	\$49	\$252	\$62	\$121	\$79	\$98	\$360
Special items:							
Costs associated with planned separation	—	—	3	16	25	34	78
Legal and other advisory costs related to Grenfell Tower	4	18	2	3	1	2	8
Strategy and portfolio review costs	7	7	6	—	—	—	6
Fasteners plant fire costs	—	—	—	4	4	1	9
Collective bargaining agreement negotiation	—	—	—	9	—	—	9
Impairment of energy business assets	—	—	—	9	—	1	10
Environmental remediation	—	—	—	25	—	—	25
Settlements of certain customer claims primarily related to product introductions	—	38	—	—	—	—	—
Arconic Inc Corporate expense excluding Special items	\$38	\$189	\$51	\$55	\$49	\$60	\$215

Arconic Inc Corporate expense excluding Special items is a non-GAAP financial measure. Management believes that this measure is meaningful to investors because management reviews the operating results of Arconic Inc excluding the impacts of Special items. There can be no assurances that additional Special items will not occur in future periods. To compensate for this limitation, management believes that it is appropriate to consider both Arconic Inc Corporate expense determined under GAAP as well as Arconic Inc Corporate expense excluding Special items.

Calculation of Arconic Inc Engineered Products and Forgings Segment Operating Profit Margin and Capital Expenditures as a Percent of Third Party Sales

(\$ in millions)	1Q18	2Q18	3Q18	4Q18	2018	1Q19	2Q19	3Q19	4Q19	2019
Segment operating profit	\$261	\$292	\$284	\$268	\$1,105	\$313	\$360	\$363	\$354	\$1,390
Third-party sales	\$1,666	\$1,734	\$1,683	\$1,715	\$6,798	\$1,756	\$1,822	\$1,794	\$1,733	\$7,105
Segment operating profit margin	15.7%	16.8%	16.9%	15.6%	16.3%	17.8%	19.8%	20.2%	20.4%	19.6%
Capital expenditures					\$407					\$344
Capital Expenditures as percent of Third Party Sales					6%					5%

Arconic Inc Engineered Products and Forgings Segment Information

Our audited consolidated financial statements as of and for the year ended December 31, 2019 are not yet complete and are not available as of the date of this presentation. On January 27, 2020, Arconic Inc. reported unaudited financial results for the year ended December 31, 2019 for its Engineered Products and Forgings (“EP&F”) segment. Our historical consolidated financial information was prepared from Arconic Inc’s historical accounting records, including the underlying financial data derived from the operations that comprise Arconic Inc’s EP&F segment. Certain financial information of Arconic Inc’s EP&F segment included in this presentation is the information of Arconic Inc’s EP&F segment as a reportable segment of Arconic Inc. Our final audited consolidated financial statements as of and for the year ended December 31, 2019 may differ from Arconic Inc’s EP&F segment’s unaudited financial results included in this presentation, and the unaudited financial results for Arconic Inc’s EP&F segment for the year ended December 31, 2019 are not necessarily indicative of our future results for any subsequent periods.

Segment performance is evaluated based on a number of factors; however, the primary measure of performance is Segment operating profit. Arconic Inc’s definition of Segment operating profit is Operating income excluding Special items. Special items include Restructuring and other charges. Segment operating profit includes the impact of LIFO inventory accounting, metal price lag, intersegment profit eliminations, and derivative activities.

Calculation of Arconic Inc Engineered Products and Forgings Segment Historical Sales Growth

(\$ in millions)	Year ended December 31,		
	2016	2017	2018
Third-party sales	\$5,890	\$6,300	\$6,798
Compound Annual Growth Rate			7%

Arconic Inc Engineered Products and Forgings Segment Information

Our audited consolidated financial statements as of and for the year ended December 31, 2019 are not yet complete and are not available as of the date of this presentation. On January 27, 2020, Arconic Inc. reported unaudited financial results for the year ended December 31, 2019 for its Engineered Products and Forgings (“EP&F”) segment. Our historical consolidated financial information was prepared from Arconic Inc’s historical accounting records, including the underlying financial data derived from the operations that comprise Arconic Inc’s EP&F segment. Certain financial information of Arconic Inc’s EP&F segment included in this presentation is the information of Arconic Inc’s EP&F segment as a reportable segment of Arconic Inc. Our final audited consolidated financial statements as of and for the year ended December 31, 2019 may differ from Arconic Inc’s EP&F segment’s unaudited financial results included in this presentation, and the unaudited financial results for Arconic Inc’s EP&F segment for the year ended December 31, 2019 are not necessarily indicative of our future results for any subsequent periods.

Reconciliation of Arconic Inc Net Debt

(\$ in millions)	December 31, 2017	March 31, 2018	June 30, 2018	September 30, 2018	December 31, 2018	March 31, 2019	June 30, 2019	September 30, 2019	December 31, 2019
Short-term debt	\$38	\$45	\$45	\$42	\$434	\$435	\$434	\$1,434	\$1,034
Long-term debt, less amount due within one year	6,806	6,309	6,312	6,315	5,896	5,899	5,901	4,905	4,906
Total debt	6,844	6,354	6,357	6,357	6,330	6,334	6,335	6,339	5,940
Less: Cash, cash equivalents, and restricted cash	2,154	1,208	1,460	1,542	2,283	1,326	1,360	1,324	1,703
Net debt	\$4,690	\$5,146	\$4,897	\$4,815	\$4,047	\$5,008	\$4,975	\$5,015	\$4,237

Net debt is a non-GAAP financial measure. Management believes that this measure is meaningful to investors because management assesses Arconic Inc's leverage position after factoring in cash that could be used to repay outstanding debt.

Reconciliation of Arconic Inc Net debt to Adjusted EBITDA Excluding Special Items

(\$ in millions)

	Trailing-12 months ended								
	December 31, 2017	March 31, 2018	June 30, 2018	September 30, 2018	December 31, 2018	March 31, 2019	June 30, 2019	September 30, 2019	December 31, 2019
Net (loss) income	\$ (74)	\$ (253)	\$ (345)	\$ (303)	\$ 642	\$ 686	\$ 445	\$ 379	\$ 470
Add:									
Provision for income taxes	544	438	455	490	226	240	92	118	105
Other (income) expense, net	(486)	(150)	23	(7)	79	91	79	102	122
Interest expense	496	495	401	389	378	349	345	343	338
Restructuring and other charges	165	99	88	67	9	14	498	619	620
Impairment of goodwill	719	719	719	719	—	—	—	—	—
Provision for depreciation and amortization	551	560	567	568	576	571	566	556	536
Adjusted EBITDA	\$ 1,915	\$ 1,908	\$ 1,908	\$ 1,923	\$ 1,910	\$ 1,951	\$ 2,025	\$ 2,117	\$ 2,191
Add:									
Costs associated with planned separation	\$ 18	\$ —	\$ —	\$ —	\$ —	\$ 3	\$ 19	\$ 44	\$ 78
Environmental remediation	—	—	—	—	—	—	25	25	25
Collective bargaining agreement negotiation	—	—	—	—	—	—	9	9	9
Impairment of energy business assets	—	—	—	—	—	—	9	9	10
Fasteners plant fire costs	—	—	—	—	—	—	4	8	9
Proxy, advisory and governance-related costs	58	42	—	—	—	—	—	—	—
Legal and other advisory costs related to Grenfell Tower	14	19	23	21	18	15	14	10	8
Settlements of certain customer claims primarily related to product introductions	—	—	38	38	38	38	—	—	—
Strategy and portfolio review costs	—	—	—	—	7	13	13	13	6
Delaware reincorporation costs	3	3	3	3	—	—	—	—	—
Adjusted EBITDA excluding Special items	\$ 2,008	\$ 1,972	\$ 1,972	\$ 1,985	\$ 1,973	\$ 2,020	\$ 2,118	\$ 2,235	\$ 2,336
Net debt	\$ 4,690	\$ 5,146	\$ 4,897	\$ 4,815	\$ 4,047	\$ 5,008	\$ 4,975	\$ 5,015	\$ 4,237
Net debt to Adjusted EBITDA excluding Special items	2.34	2.61	2.48	2.43	2.05	2.48	2.35	2.24	1.81

Arconic Inc's definition of Adjusted EBITDA (Earnings before interest, taxes, depreciation, and amortization) is net margin plus an add-back for depreciation and amortization. Net margin is equivalent to Sales minus the following items: Cost of goods sold; Selling, general administrative, and other expenses; Research and development expenses; and Provision for depreciation and amortization. Management believes that this measure is meaningful to investors because it provides additional information with respect to Arconic Inc's operating performance and the Company's ability to meet its financial obligations. The Adjusted EBITDA presented may not be comparable to similarly titled measures of other companies.

Net debt is a non-GAAP financial measure. Management believes that this measure is meaningful to investors because management assesses Arconic Inc's leverage position after factoring in cash that could be used to repay outstanding debt.

Reconciliation of Howmet Aerospace Pro Forma Adjusted EBITDA Margin and Net Debt to Adjusted EBITDA

(\$ in millions)	2019
Arconic Inc Engineered Products & Forgings – Segment operating profit	\$1,390
Arconic Inc Engineered Products & Forgings – Provision for depreciation and amortization	269
Allocation of Arconic Inc Corporate expenses	(100)
Adjusted EBITDA	\$1,559
Third-party sales	\$7,105
Adjusted EBITDA margin	22%
Allocation of Arconic Inc Net Debt	\$3,437
Net Debt to Adjusted EBITDA	2.2x

Adjusted EBITDA is a non-GAAP financial measure. Management believes that this measure is meaningful to investors because this measure provides additional information with respect to historical operating performance and the company's ability to meet its current and future obligations.

Net debt is a non-GAAP financial measure. Management believes that this measure is meaningful to investors because management assesses Arconic Inc's leverage position after factoring in cash that could be used to repay outstanding debt.

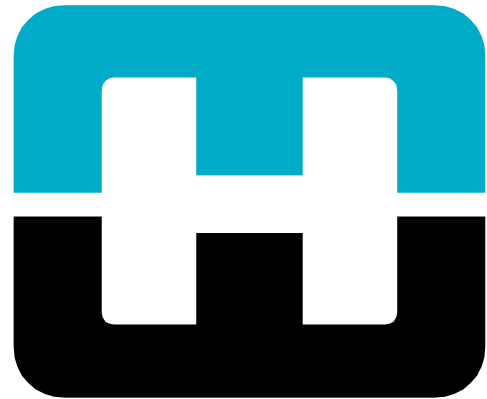

**HOWMET
AEROSPACE**